

Solutions for Your TOUGHEST
MIXING Applications in

FOOD



Manufacturing Tomato
Sauces and Ketchups



Manufacturing Tomato Sauces and Ketchups

Tomato sauces are used in many products including frozen foods, pasta sauces and pizza toppings, etc. A typical tomato sauce would be based on sieved or whole tomatoes, and/or tomato paste. It would also contain water, sugar, vinegar, salt and seasoning. The desired product viscosity would normally be achieved using a starch-based thickener.

Tomato ketchup is a condiment manufactured from similar ingredients, although paste is used rather than whole tomatoes. Premium quality ketchups with a high solids content derive their viscosity from a combination of water retention of the fibrous strands in the paste and the gelling effect of pectin found naturally in tomatoes. High pressure homogenisation is also used to obtain the desired viscosity. This is common with lower solids content ketchups, which may also contain starch-based thickeners.

The Process

The recipe, viscosity and solids content of sauces and ketchups vary widely according to the end use. Typical process requirements are as follows:

- Mixing apparatus must be capable of dispersing powdered ingredients into water to form an agglomerate-free product.
- If the product is made from whole peeled tomatoes, these require chopping and pulping before addition to the mix.
- Insoluble particles in the tomatoes need to be fully dispersed and “milled” to obtain a smooth texture and even dispersion of the pigment (carotin) to give depth of colour.
- Fibrous strands in the tomatoes must be fibrillated (frayed) to raise capacity for water retention, which increases viscosity.
- Once mixed, the product may be passed through a high pressure homogeniser or colloid mill to obtain the required consistency.

The Problem

A number of problems can be encountered when using conventional agitators:

- Additives designed to thicken the product tend to form agglomerates which agitators cannot easily break down.
- Partially hydrated ingredients can build up on the vessel wall and parts of the mixer.
- Long mixing times are required to achieve complete dispersion.
- Long mixing times are required to dilute tomato paste into water, as agitators cannot easily blend liquids of widely differing viscosity.
- A uniform pre-mix is required by the homogeniser. This is not easily achieved using agitators.
- Several runs through the homogeniser or mill may be required to obtain the desired product.
- Excessive homogenisation pressure can break down fibres, damaging water retention properties, causing separation and adversely affecting colour.
- Homogenisation and other handling can dull the finish of ketchups.
- Tomato pips contained in products using whole tomatoes can be crushed during milling, imparting a bitter taste.

The Solution

A Silverson high shear mixer can solve these problems and eliminate the need for additional processes such as chopping and in some cases homogenisation. A Silverson mixer can be used throughout the entire manufacturing process of sauces. With ketchups, the high shear mixing action will also improve pre-mix quality and consistency. Operation is as follows:

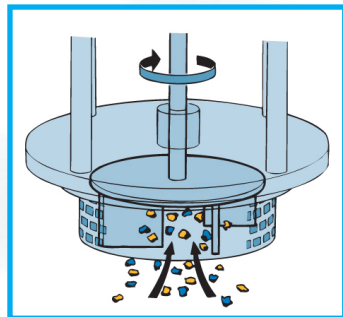

Stage 1

The vessel is charged with water and the Silverson mixer is started. The powdered ingredients are then added. The high speed rotation of the Silverson Mixer creates a powerful suction which draws the liquid and powders into the workhead. The materials are subjected to intense shear within the workhead.

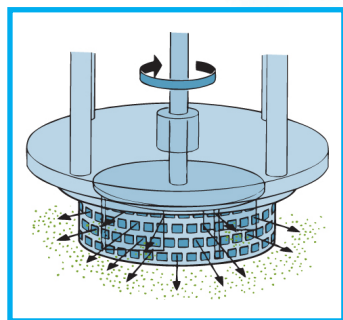

Stage 2

Agglomerates are broken down between the ends of the rotor blades and the stator wall. The product is forced out through the stator and returned to the mix. Fresh materials are simultaneously drawn into the workhead, maintaining the mixing cycle. The circulatory mixing pattern ensures that hydration of the thickening agents is rapidly completed.

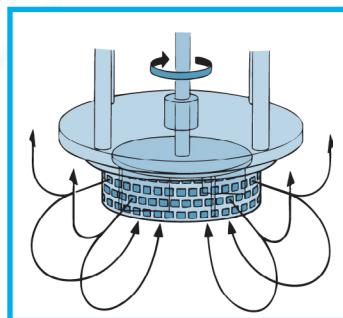

Stage 3

The tomato paste is then added and dispersed in the same manner. Whole peeled tomatoes can be added to sauce mixes. These are disintegrated by the Silverson mixer without prior chopping or pulping being required. The insoluble particles are finely reduced and dispersed throughout the product. A homogeneous mixture is rapidly obtained.

The Advantages

- Dramatically reduced processing times.
- Rapid dispersion of thickeners and stabilisers.
- Improved yield of ingredients.
- Smoother texture and improved product consistency.
- Improved colour.
- The product fed to the homogeniser is uniform and of a low particle size, allowing faster processing through the homogeniser and fewer passes required.
- Some sauces with low solids content may not require homogenisation.
- Special “low shear” heads available for processing whole tomatoes to eliminate risk of milling pips.
- A Silverson mixer can be used as a “polishing step” after homogenisation to improve texture, viscosity and sheen of ketchup.

The type of product, batch size and viscosity of the end product determine which mixer from the Silverson product line is most suitable:

High Shear Batch Mixers

- Suitable for batches of up to 500 litres
- Larger batches can be processed with additional in-tank agitation
- Easily cleaned
- Can be either vessel mounted, or fitted to a mobile hydraulic floor stand

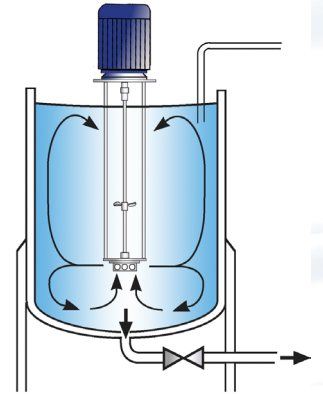

High Shear In-Line Mixers

- Ideal for larger batches
- Aeration free
- Easily retrofitted to existing plant
- Self-pumping
- Can be used to discharge vessel
- Designed to be Cleaned-In-Place
- Multistage units available for greater degree of shear resulting in finer particle size and faster processing times
- Tomato paste dilution can be carried out on a continuous basis as shown
- High Viscosity models available

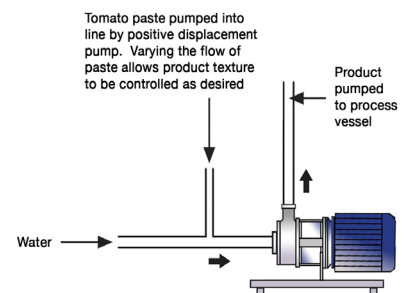
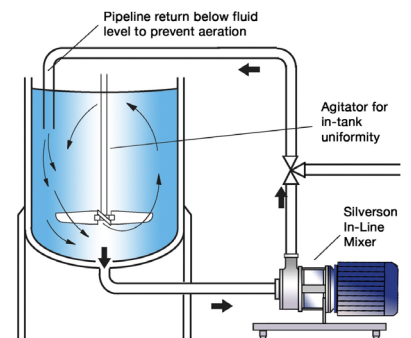

Silverson Flashmix

- Ideal for larger sauce batches
- Capable of rapidly incorporating starch, sugar, salt and spices
- Minimised aeration
- Minimised cleaning requirements
- Suitable for higher viscosity mixes
- Suitable for operation at higher temperatures
- Minimum operator input required
- If whole tomatoes are used, these can be pumped directly into the fluid stream

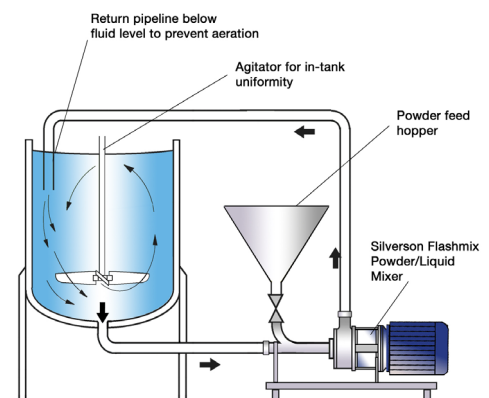

For more information click here to go to www.silverson.co.uk

Silverson Machines Ltd. Waterside, Chesham, Buckinghamshire England HP5 1PQ
Tel: +44 (0) 1494 786331 Email: sales@silverson.co.uk

Information contained in this report is believed to be correct and is included as a guide only. No warranty is expressed or implied as to fitness for use or freedom from patents. Silverson Machines reserve the right to change product specification without notice.

Issue No. 24FE4